

Transformer Ratios Measured Directly on the Quadtech 1689 and 1693 Digibridge™

The 1689 Precision RLC Digibridge can measure voltage ratio directly using the connection shown in Figure 1. This method is particularly suitable for inductance voltage dividers that could be formed by any two windings of a transformer connected as series aiding. The Digibridge resistance readout indicates the real part of the voltage ratio.

In Figure 1, the Digibridge is actually measuring the auxiliary resistor R_p , but the potential connections are across the divider so that the measured E_x is $g(E_x)$, where g is the divider ratio. Therefore the indicated resistance is $g(R_p)$. To make the Digibridge direct reading in g , R_p should be set to an even decade value, say 1.0000k Ω . To do this, R_p may be a precision resistance, or it may be adjustable and set to give a reading of 1.0000k Ω when g is unity (i.e., the P+ and I+ are both connected to the divider input).

The ratio mode of the Digibridge makes it possible to use a stable resistor of any value as R_p . First, measure R_p with the PH connector tied to the IH connector. Then note the resistor value. Enter this at the NOMINAL VALUE and go to the RATIO value ([2] [=] [SHIFT] [SPECIAL] [6]). Now, when PH is tied to the junction of the windings, the 1689 will read g directly. The main source of error, and it is small, is caused by lead resistance and finite inverter amplifier gain. The effective value of R_p is:

$$R_p \left(1 + \frac{r}{R_p} + \frac{r}{1+K} \right)$$

where r is lead resistance and K the amplifier gain at the test frequency. This error is removed if R_p is adjusted to give a reading of 1.0000 when $g = 1$. Perhaps the most useful application is in measuring transformer turns ratios. In this case

$$g \cong \frac{N_2}{N_1 + N_2} \left(1 + \frac{N_1(N_1 Z_2 - N_2 Z_1)}{(N_1 + N_2) Z_m} \right)$$

where Z_1 and Z_2 are the leakage impedances of the two windings and Z_m is the mutual impedance between them. The error term is usually very small (particularly if the same wire size is used for both windings so that the winding resistances are proportional to the number of turns). The Digibridge should be set to measure Series Resistance and the measured resistance used to calculate g .

Measurement Procedure

It is useful to note that these are several of the methods of measuring turn ratios of transformers but these all require at least two measurements and a calculation. The method described above is particularly good for production tests if the turns-ratio ($N1/N2$) limits are converted to limits as $N2/(N1+N2)$ because, as setup, no future adjustments or calculations are required.

This application note describes a method to measure the turns-ratio of a transformer using a QuadTech digibridge. Briefly stated, the method measures a precision resistor and uses the transformer, connected series aiding, as a divider to determine the ratio.

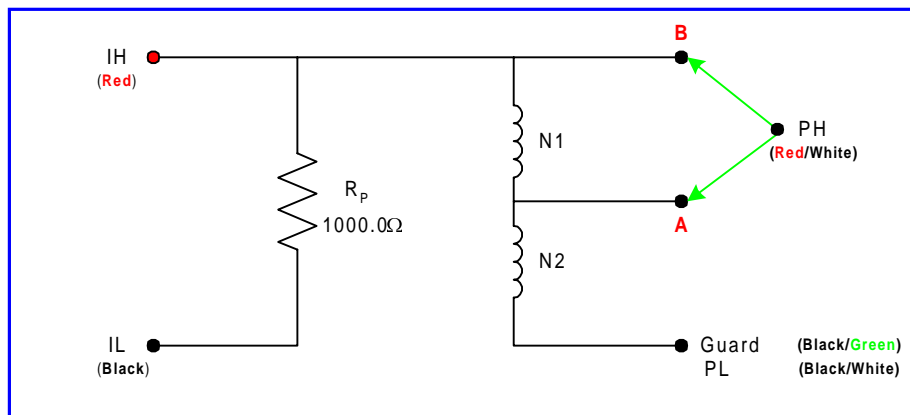

Figure 1: Test Setup

A) PROCEDURE FOR ANY DIGIBRIDGE:

1. Connect the test setup as shown with PH set to position **B**.
2. Press R/Q and measure R to be 1000.0Ω . Use a precision resistor or decade box to get this value as close as possible.
3. Connect PH to position **A**.
4. Measure the resistance and insert the value in the equation:

$$\frac{N1}{N2} = \frac{1000.0 - \text{reading}}{\text{reading}}$$

Measurement Procedure

B) ALTERNATE PROCEDURE FOR 1689: (using RATIO mode)

1. Connect the test setup as shown with PH set to position **B**.
2. Press R/Q and measure R to be 1000.0Ω. Use a precision resistor or decade box to get this value as close as possible.
3. Connect PH to position **A**.
4. Store the value measured in step 2 as the NOMINAL VALUE (1000Ω).
5. Enter the RATIO MODE: [1] [=] [SHIFT] [SPECIAL] [6]
6. Measure the value and insert in the equation:

$$\frac{N1}{N2} = \text{reading} - 1$$

C) ALTERNATE PROCEDURE FOR 1693: (using Conductance and delta RLC)

1. Connect the test setup as shown with PH set to position **B**.
2. Press R/Q and measure R to be 1000.0Ω. Use a precision resistor or decade box to get this value as close as possible.
3. Connect PH to position **A**.
4. Store the value measured in step 2 as the NOMINAL VALUE (1000Ω).
5. Set Display to G/B and Delta RLC.

$$\frac{N1}{N2} = \text{reading}$$



Figure 2: QuadTech 1689 and 1693 Digibridge Instruments

For complete product specifications on the 1600 Series Digibridge Line or any of QuadTech's products, visit us at <http://www.quadtech.com/products>. Do you have an application specific testing need? Call us at 1-800-253-1230 or email applications at jkramer@quadtech.com and we'll work with you on a custom solution. Put QuadTech to the test because we're committed to solving your testing requirements.

The information presented here is subject to change and is intended for general information only

©QuadTech, Incorporated

Telephone: 1- 800-253-1230, Website: <http://www.quadtech.com>

Printed in U.S.A.

P/N 035044

January 2001